

Rotary Table PR4 ELECTRIC

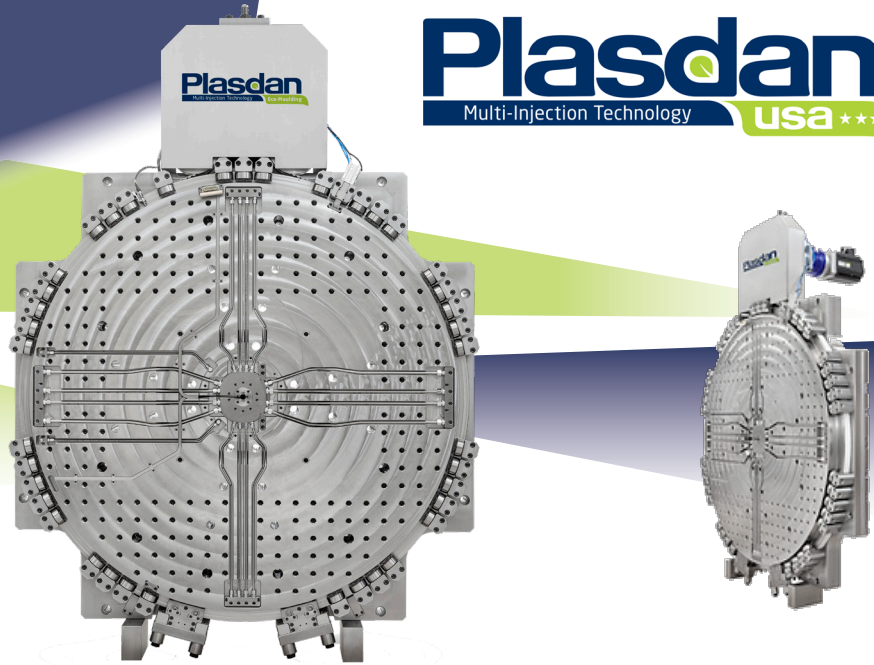

The Industry Standard

- Up to 4 cooling circuits
- Up to 4 hydraulic circuits
- Configured mold bolt pattern
- Redundant position confirmation
- 2-shot (180) or 3-shot (120)
- Slim and High Temperature Versions

DIMENSIONS	Units	PR4.0500	PR4.0550	PR4.0600	PR4.0650	PR4.0700	PR4.0750	PR4.0800	PR4.0850	PR4.0900	PR4.0950	PR4.1000	PR4.1050	PR4.1100	PR4.1150	PR4.1200
Number of cooling circuits		2	2	2	2	2	2	4	4	4	4	4	4	4	4	4
Number of oil circuits		2	2	2	2	2	2	4	4	4	4	4	4	4	4	4
Max tool weight [P]	Kg lbs	477 1051,6	501 1104,5	671 1479,3	812 1790,2	1054 2323,7	1339 2952,0	1804 3977,1	1971 4345,3	1926 4246,1	2148 4735,5	3020 6658,0	3500 7716,2	3836 8453,4	4288 9453,4	4785 10549,1
Distance to mould C.G.[A]	mm in	190 7,480	199,5 7,854	171 6,732	171 6,732	164 6,457	190 7,480	204,3 8,043	209 8,228	204,3 8,043	213,75 8,415	237,5 9,350	247 9,724	270,8 10,661	273 10,748	320 12,598
Weight of rotary table	Kg lbs	388 855,4	453 998,7	496 1093,5	577 1272,1	672 1481,5	760 1675,5	1195 2634,5	1375 3031,4	1400 3086,5	1596 3518,6	1749 3855,9	1954 4307,8	2102 4634,1	2293 5055,2	2486 5480,7
Rotation time	S	2.0	2.0	2.0	2.0	2.0	2.0	3.0	3.0	3.0	3.0	3.0	3.0	3.0	3.0	3.0
A	mm in	950 37,402	935,5 36,831	963 37,913	970 38,189	1146 45,118	1110 43,701	1170 46,063	1250 49,213	1353 53,268	1420 55,906	1457 57,362	1505 59,252	1555 61,220	1600 62,992	1630 64,173
B	mm in	619,5 24,390	657 25,866	705 27,756	740 29,134	806 31,732	850 33,465	930 36,614	1000 39,370	100 3,937	1064 41,890	1112 43,780	1161 45,709	1200 47,244	1270 50,000	1320 51,969
C	mm in	389 15,315	390 15,354	450 17,717	470 18,504	470 18,504	485 19,094	595 23,425	635 25,000	680 26,772	700 27,559	686,5 27,028	781,5 30,768	735 28,937	780 30,709	820 32,283
D	mm in	640 25,197	690 27,165	700 27,559	750 29,528	820 32,283	860 33,858	925 36,417	975 38,386	1020 40,157	1050 41,339	1095 43,110	1160 45,669	1200 47,244	1250 49,213	1300 51,181
E	mm in	424 16,693	430 16,929	400 15,748	480 18,898	524 20,630	535 21,063	545 21,457	615 24,213	670 26,378	690 27,165	775 30,512	750 29,528	830 32,677	860 33,858	880 34,646
F	mm in	160 6,299	160 6,299	160 6,299	160 6,299	160 6,299	160 6,299	215 8,465	215 8,465	215 8,465	215 8,465	215 8,465	215 8,465	215 8,465	215 8,465	215 8,465
G	mm in	413,5 16,280	448,5 17,657	406,5 16,004	415 16,339	545 21,457	483,5 19,035	500 19,685	583,5 22,972	605,5 23,839	632,5 24,902	656,5 25,846	680 24,772	705 27,756	732,5 28,839	758,5 29,862
H	mm in	380 14,961	346 13,622	433 17,047	403 15,866	434 17,087	434 17,087	365 14,370	405 15,945	397 15,630	399 15,709	397 15,630	435 17,126	429 16,890	430 16,929	430 16,929
I Ø	mm in	500 19,685	550 21,654	600 23,622	650 25,591	700 27,559	750 29,528	800 31,496	850 33,465	900 35,433	950 37,402	1000 39,370	1050 41,339	1100 43,307	1150 45,276	1200 47,244

DIMENSIONS	Units	PR4.1250	PR4.1300	PR4.1350	PR4.1400	PR4.1450	PR4.1500	PR4.1700	PR4.1750	PR4.1800	PR4.1850	PR4.1900	PR4.2400	PR4.2500
Number of cooling circuits		4	4	4	4	4	4	4	4	4	4	4	4	4
Number of oil circuits		4	4	4	4	4	4	4	4	4	4	4	4	4
Max tool weight [P]	Kg lbs	4785 10549,1	5146 11345,0	5485 12092,3	5760 12698,6	6136 13527,5	6607 14565,9	8155 17978,7	8155 17978,7	8770 19334,5	9094 20048,8	9061 19976,1	12791 28199,3	14224 31358,5
Distance to mould C.G.[A]	mm in	320 12,598	327,8 12,906	332,5 13,091	308,75 12,156	323 12,717	332,5 13,091	285 11,220	285 11,220	285 11,220	285 10,846	275,5 10,911	256,3 11,783	313,5 12,343
Weight of rotary table	Kg lbs	2717 5990,0	2700 5952,5	3082 6794,6	3360 7407,5	3592 7919,0	3922 8646,5	6015 13260,8	6215 13701,7	6561 14464,5	6850 15101,6	7329 16157,7	15776 34780,1	17456 38483,8
Rotation time	S	3.0	3.0	4.0	4.0	4.0	4.0	4.5	4.5	4.5	4.5	4.5	4.5	4.5
A	mm in	1705 67,126	1895 74,606	2091,5 82,343	2142 84,331	2030 79,921	2200 86,614	2667 105,000	2675 105,315	2730 107,480	2791 109,882	2851 112,244		
B	mm in	1370 53,937	1420 55,906	1470 57,874	1520 59,843	1570 61,811	1620 63,780	1825 71,850	1875 73,819	1925 75,787	1945 76,575	1995 78,543		
C	mm in	840 33,071	880 34,646	900 35,433	920 36,220	791 31,142	980 38,583	1100 43,307	1165 45,866	1200 47,244	1180 46,457	1280 50,394		
D	mm in	1370 53,937	1420 55,906	1455 57,283	1540 60,630	1611 63,811	1620 63,780	1875 73,819	1875 73,819	2000 78,740	2040 80,315	2090 82,283		
E	mm in	909 35,787	940 37,008	940 37,008	1060 41,732	1040 40,945	1100 43,307	1330 52,362	1350 53,150	1400 55,118	1420 55,906	1350 53,150		
F	mm in	215 8,465	215 8,465	215 8,465	215 8,465	215 8,465	215 8,465	265 10,433	265 10,433	265 10,433	265 10,433	265 10,433		
G	mm in	759 29,882	788,5 31,043	950,5 37,421	976 38,425	864,5 34,035	985 38,780	1205 47,441	1300 51,181	1300 51,181	1310 51,575	1320 51,969		
H	mm in	411 16,181	465 18,307	465 18,307	467 18,386	345 13,583	345 13,583	465 18,307	465 18,307	465 18,307	465 18,307	465 18,307		
I Ø	mm in	1250 49,213	1300 51,181	1350 53,150	1400 55,118	1450 57,087	1500 59,055	1700 66,929	1750 68,898	1800 70,866	1850 72,835	1900 74,803		

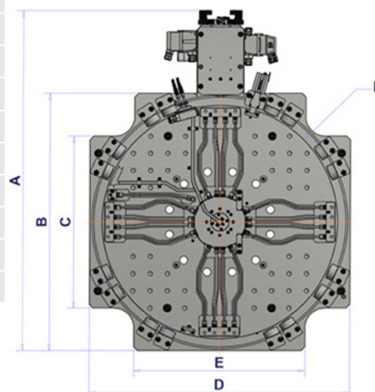

+1 (833) PLASDAN 752-7326 info@plasdanusa.com www.plasdanusa.com

PLASDAN USA
1239 Springwood Church Rd
Gibsonville, NC 27249